

Explosion Proof Fluorescent Tube

CS-EXTBL-2-36

Pictures

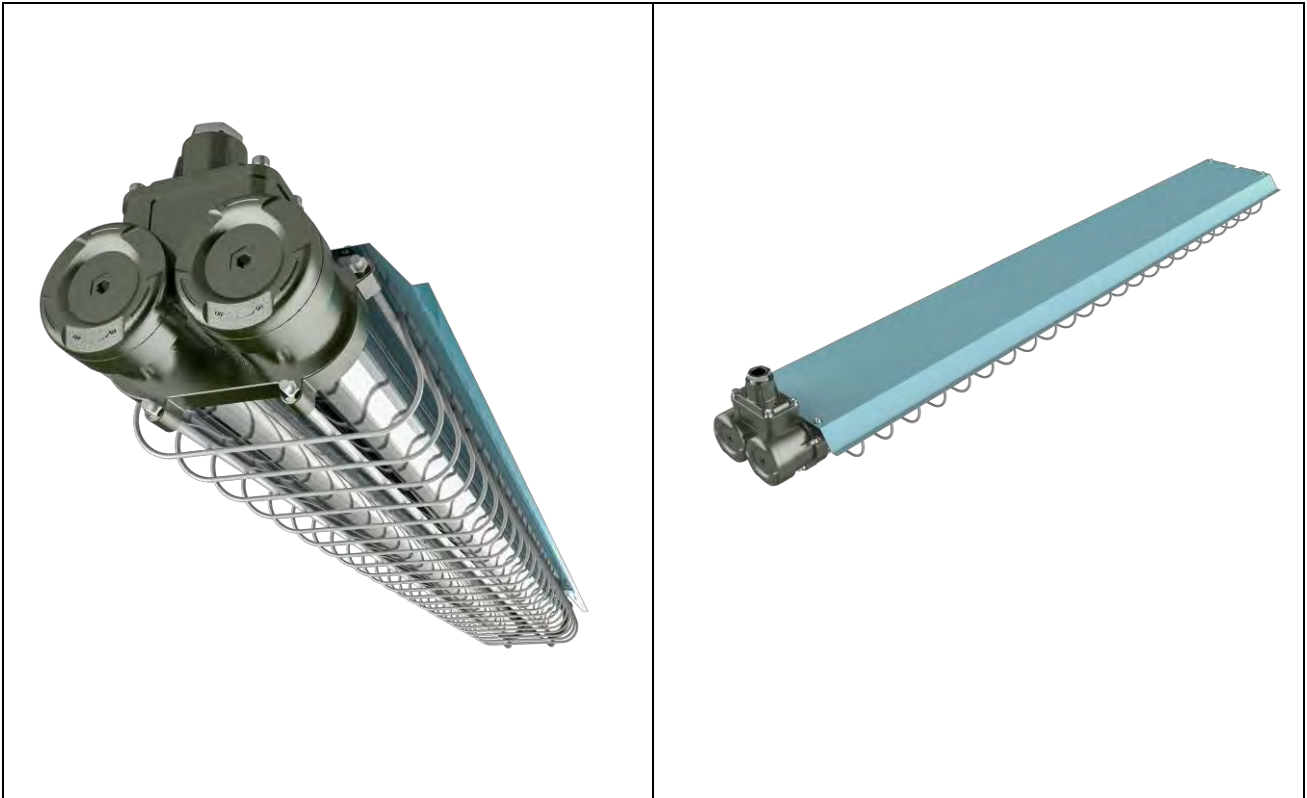

Features

1、 Application scenario

This product is suitable for dangerous places in zones 1 and 2, explosive gas environments of Class II A, II B and II C, mixing temperature of explosive gases: T1~T5, widely used in dangerous environments such as petroleum, chemical industry, military industry, medicine, mine, working and scene lighting of dangerous places such as offshore oil platforms, oil tankers, etc.

2、 Product Features

- 1、 Products can work safely in various flammable and explosive places.
- 2、 Cast aluminium alloy shell, surface spraying anti-static, corrosion-resistant, waterproof,

Shenzhen Cresea Technology Co.,Ltd

Website:www.cressaled.com

Email: info@cressaled.com

Tel: +86 755 27063335

dust-proof, can be used in high temperature, humidity and various corrosive harsh environments for a long time;

3、 Transparent toughened glass protective cover, good light transmittance, impact resistance, high light flux, energy saving, environmental protection and other advantages.

4、 Beautiful appearance, simple and reliable structure, easy installation; structural steel pipe or cable wiring can be;

5、 Independent wiring cavity design makes wiring more convenient and fast.

Product parameters

ITEM	symbol	Description	UNIT
Rated Voltage	VOLT	220	V
Power	P	2*16	W
Protection Level	IP	IP65	IP
Lighting Angle	θ	360	°
Light source specifications	/	T8荧光 灯管	3030
LED Qty		/	360
Anticorrosion grade	/	WF2	
Explosion proof grade	/	Ex d IIB T6 Gb/Ex tD A21 IP66 T80°C	
Light efficiency	η	>90	>120 Lm/W
Frequency	f	50/60	Hz
Power Factor	PF	>0.95	PF
Operating Temperature	TOPR	-20~40	°C
Light Source	/	led	PCS
Correlate Color Temperature	CCT	3000K-6500	K
Color Rendering Index	CRI	≥ 70	RA
LED'S Operating Life	LIFE	50000	Hours
Start-up time	T	≤ 0.2	S
Executive standard	/	GB3836.1、GB3836.2	
Size	/	1280*202*146	MM
weight	/	5.4	KG

Dimensions

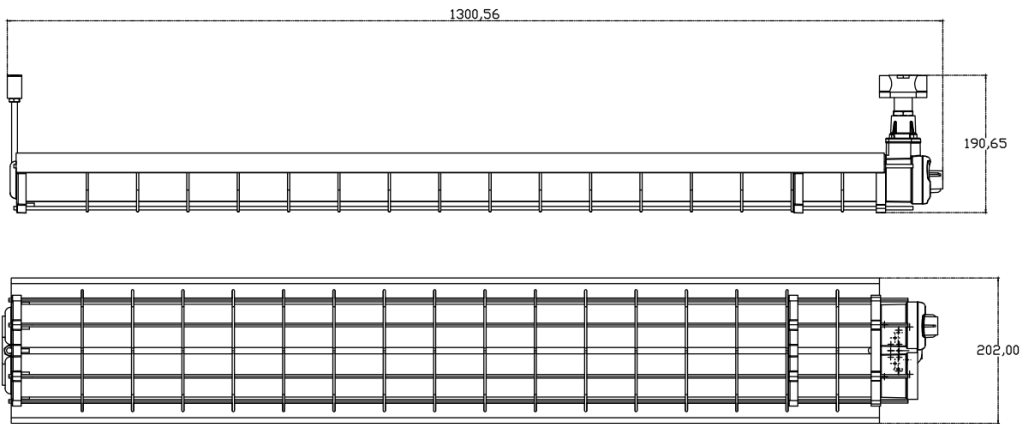

Installation

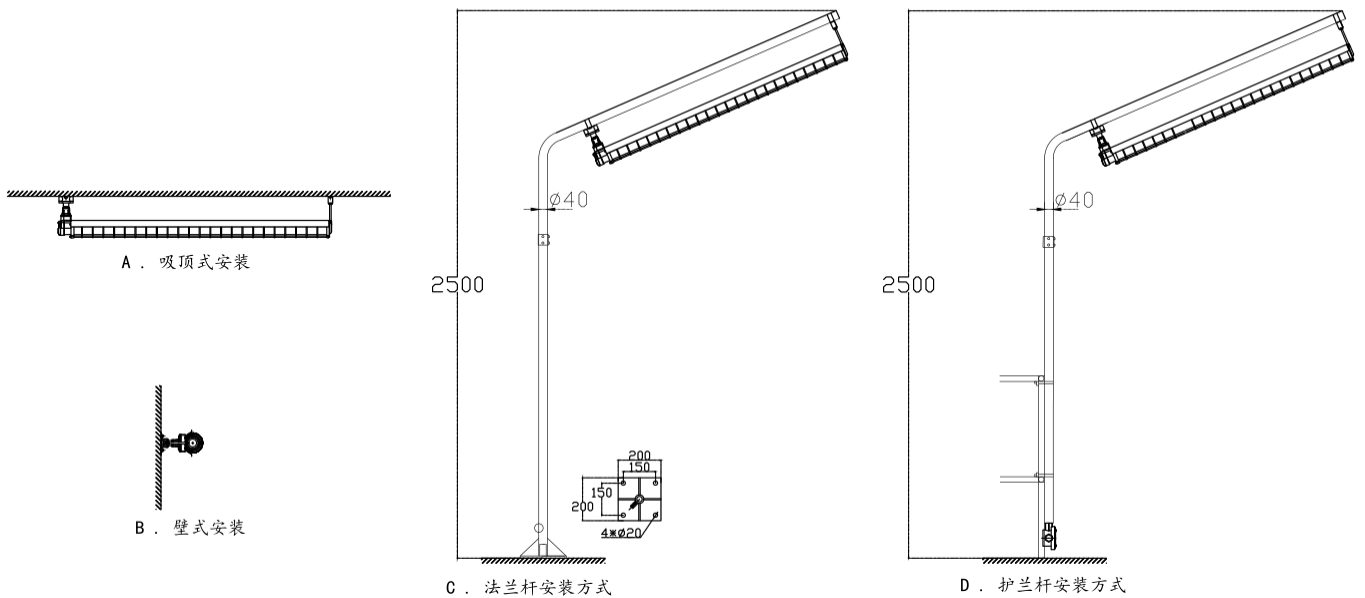

Package

Name	Description	(pcs) Quantity	Name	Parameter
Outer box	137*23.5*20.7cm	1	N. W.	10.8kg
Foam	222*147*70mm	4	G. W.	11.5kg
Packaging method		2pcs/CTN		

Caution

1、 Schematic diagram

1. When installing and maintaining lamps and lanterns, the power supply must be disconnected first.
2. Non-professionals are not allowed to disassemble lamps and lanterns at will.
3. When used, there is a certain temperature rise on the surface of lamps and lanterns, which is a normal phenomenon; the central temperature of transparent parts is higher, so it is not allowed to touch directly with hands.

Warning:

- 1.Do not install directly on combustibles.
- 2.Replace any cracked protective screen.
- 3.Lamps must be grounded reliably.

2、 Using The Matters Needing Attention

- 1、 transport lights should be installed in the cartons equipped with foam shock absorption.
- 2、 The power supply voltage can work normally within the prescribed range, too high the power supply voltage will damage the lamps; too low the voltage will cause the lamps can not start normally.

3、 Quality Assurance

The company has passed ISO9001:2008 international quality system audit certification, this product strictly implements ISO9001 international quality management system standard production, to ensure that the product quality fully meets national standards and design requirements.